



Grid Solutions
a GE and Alstom joint venture

OSKF

Current transformers 72.5 kV to 765 kV

For years, grid operators have trusted the OSKF current transformers made by Grid Solutions and thousands are installed in substations around the world. Customers recognise the top-of-the-line CTs for their long-term strength, safety and reliability for voltages up to 800 kV.

Designed to meet our customers highest expectations

LONG SERVICE LIFE AND NEAR ZERO MAINTENANCE

OSKF current transformers have been designed for a 30 year lifetime and, thanks to the soundness of our technical concepts, many well out-live this service life.

They have near-zero maintenance requirements: the oil is hermetically sealed from the air by a stainless steel diaphragm assembly and all external parts are of corrosion-resistant material.

METERING – PROTECTION

CHARACTERISTICS

- High quality paper-oil insulation
- Top core design with metal head
- Oil expansion by stainless steel diaphragm bellows
- Oil level indicator
- Secondary cores in aluminium box
- Changing of primary ratio by primary series-parallel connection (double or triple ratio) or by secondary taps.

PERFORMANCE

- U_n : 72.5 to 765 kV
- I_n : up to 5,000 A
- I_n : short-circuit: up to 80 kA (I_{sc} dyn: 200 kA peak)
- Secondary cores: up to 8

SEISMIC WITHSTAND CAPABILITY

Standard design up to 0.5 g (higher values on request)

Compliance with IEC, ANSI/IEEE or equivalent standards. Other standards on request.

CUSTOMER BENEFITS

- Extensive field experience, incl. highly seismic regions
- Special accuracy classes for protection: TPS, TPX, TPY, TPZ, PR
- Mineral oil-filled: no PCB
- Operational security
- Stable accuracy over a long period of time
- Built for long life



Linking the power chain

TOP CORE DESIGN AND PRIMARY WINDINGS

The 'inverted CT' design, with active parts in the head, offers particular advantages for higher currents. The primary is normally a straight bar type conductor. Ratio change can be accomplished either by primary series-parallel connection (double or triple ratio) or by secondary taps. Combinations of series-parallel connection and secondary taps are also possible. This maintains the output and accuracy of the secondaries at all ratios. The top core design also has the advantage of spreading the primary winding in a uniform and symmetrical way around the cores, avoiding local saturation and reducing the leakage flux.



CORES AND SECONDARY WINDINGS

Current transformers can have several toroidal laminated cores which are independent of each other. The cores with the secondary winding are accommodated in a thick-walled, round core aluminium protection.

The core housing is connected to a strong metal pipe inside the insulator which leads to the base plate. Cross sections and connections have been dimensioned in such way that the current can be led to the ground in case of internal failure, avoiding an arc inside the insulator.

HIGH QUALITY PAPER-OIL INSULATION

Insulating paper is applied to the core housing and its supporting tube by a special wrapping machine to ensure high density and uniform insulation.

An extremely low residual humidity is obtained by a special paper insulation drying process. Grading layers with well-rounded edges give a uniformly distributed field over the entire unit. Only the highest quality mineral oil with excellent durability and gas-absorbing properties is used. The insulating oil contains no PCB.

Controlled vacuum and temperature treatments withdraw humidity and gas from the paper insulation and insulation oil; the impregnation process results in a high-grade dielectric system.

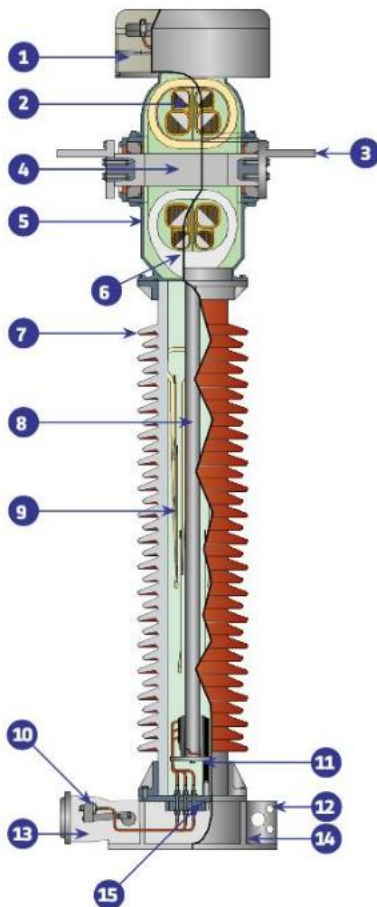

1. Diaphragm bellows
2. CT cores
3. HV primary terminal
4. Primary conductor assembly
5. Head housing
6. Core housing
7. Porcelain insulator
8. Bushing tube
9. Capacitive grading layers
10. Secondary terminal blocks
11. Fault current carrying connector to ground
12. Ground pad
13. Secondary terminal box
14. Base assembly
15. Sealing plate

HERMETICALLY SEALED

The OSKF maintains a completely sealed and pressure free system through the use of a stainless steel metallic diaphragm assembly. The diaphragm assembly provides oil expansion and pressure compensation, protects the interior from air and moisture and preserves the dielectric strength of the unit. The movements of the diaphragm assembly are translated to an indirect oil level indicator which is visible behind a window in the diaphragm cover.

LEAKPROOF DESIGN

The head housing is made of corrosion-proof aluminum alloy. Every housing is subjected to a vacuum leak test by helium leak detection. An overall leak test is performed on every completely assembled unit before oil filling.

PRIMARY TERMINALS

The standard primary terminals consist of aluminium flat terminal pads with 4, 6, 8, or more holes. On request, single or double round terminals made of nickel-plated-copper can be provided.

SECONDARY TERMINAL BOX

The terminal box is very spacious and has a removable plate located at the bottom which allows for in-factory or on-site drilling of the conduit entrances for the insertion of cable glands as desired.



INSULATOR

The outer insulation consists of high-quality oxide porcelain in brown (RAL 8016) or grey (ANSI 70). Standard creepage distances are available according to the dimension tables. Larger creepage distances and composite insulators are available on request.

PROTECTION AGAINST BURSTING

The optimised insulation structure and appropriate structural measures secure the high-grade dielectric for a very long time. The following additional measures are taken to prevent the porcelain from bursting in the event of an inner insulation breakdown, e.g., in case of lightning strikes:

- The active part is above the porcelain in an aluminium head housing.
- An internal fault current connection is provided between the core housing and the ground terminal on the base.
- A pressure relief plate exists in the area of the expansion body on the head.
- Upon request, a composite insulator consisting of fiberglass reinforced pipe and silicone rubber screens can be provided instead of the porcelain porcelain insulator.

EARTHQUAKE-PROOF DESIGN

The standard OSKF resists medium intensity seismic events. More stringent seismic design requirements can be met upon special request.



TESTING

Testing is in conformance with national and international standards. Along with the power-frequency test, capacitance, dielectric loss factor and inner partial discharges are also measured as routine tests. Tests certificates are issued and supplied with the equipment.

ADDITIONAL INFORMATION

Dielectric loss factor:

$\tan\delta$ smaller than 0.005 up to the power-frequency test voltage

Radio Influence Voltage (RIV):

Less than 2,500 μV at $A.1 U_m$

Internal partial discharge:

Less than 10 pC at $1.2 U_m$

Frequency:

50 Hz or 60 Hz or 16 2/3 Hz.
Other value on request.

Ambient temperature:

-35°C...+40°C on a 24h average.
Other designs can be provided upon request for temperatures ranges falling outside of the mentioned range, i.e. -50°C to +50°C

Mechanical strength:

According to IEC 60044-1.
Other values on request.

DIMENSIONS

The following dimensions refer to standard versions. Other U_m values affect other dimensions.

The head size can change, depending on the core data and the primary nominal current. With regard to the creepage distance and clearance, the insulator can be adapted to the customers' request.

DIMENSIONS

Type	OSKF 72.5	OSKF 123	OSKF 145
Head size	1	1	3 A
Maximum system voltage (U_m)	kV	72.5	123
Impulse test voltage (BIL)	kV	350	550
Standard creepage distance (*)	mm	1,440	2,590
Dimensions mm	A	1,630	2,055
	B	1,260	1,690
	C	590	1,020
	D	260	260
	E	740	740
	F	450	450
Total weight (approx.)	kg	245	285
Weight of oil (approx.)	kg	43	49

Indicatives value only - All indicated dimensions must be confirmed with order.
 (*) - Standard creepage distance (mm) - Other value on request.

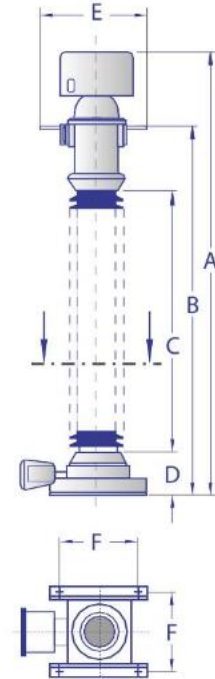

DIMENSIONS

Type	OSKF 170	OSKF 245	OSKF 362	OSKF 420	OSKF 550	OSKF 765
Head size	3 A	3 A	3 A	4 A	3 A	4 A
Maximum system voltage (U_m)	kV	170	245	362	362	420
Impulse test voltage (BIL)	kV	750	1,050	1,300	1,300	1,425
Standard creepage distance (*)	mm	4,425	5,170	7,900	7,900	9,960
Dimensions mm	A	1,620	3,530	4,525	4,800	5,275
	B	2,120	2,900	3,890	3,965	4,635
	C	1,350	2,030	3,025	2,995	3,765
	D	285	385	385	330	375
	E	900	900	900	935	1,075
	F	450	600	600	600	900
Total weight (approx.)	kg	505	775	1,010	1,270	1,395
Weight of oil (approx.)	kg	108	190	225	295	340

Indicatives value only - All indicated dimensions must be confirmed with order.
 (*) - Standard creepage distance (mm) - Other value on request.

INQUIRY CHECK LIST

- Applicable standards
- Rated frequency
- Highest system voltage
- Test voltages (power frequency, lightning impulse)
- Primary/secondary rated currents
- Short time current and duration
- Core rating (burden, accuracy)
- Environmental conditions (altitude, temperatures, pollution, seismic conditions...)
- Options:
 - Composite insulator
 - Surge arrester on secondary winding
 - Ground cable connector
 - Primary terminal
 - Specific design for use in highly active seismic regions
- Available accessories:
 - Tgδ tap
 - Oil sampling valve
 - Lifting bar
 - Oil sampling tools kit
 - Shock indicators during shipment

For more information please contact
 GE Grid Solutions

Worldwide Contact Center
 Web: www.GEGridSolutions.com/contact
 Phone: +44 (0) 1785 250 070

www.GEGridSolutions.com

